

QA600A SERIES ON-BOARD SEAL CHARGER

This series chargers design of sealed structure. It suitable for flooded lead acid batteries, sealed lead acid batteries, Lithium batteries, NI-MH batteries, Nickle Cadmium batteries, etc. They ate used to cycle charge or floating charge battery pack in electric Bumper Car, Walk-behind Mowers, fork lifts, Floor Scrubber, AGV, ships, Electric Sweeper, Golf car, Electric Aerial Work Platform, Walk-behind Mowers

Models	Rated Voltage for Battery Pack	Output Voltage Range	Max Output current	CV			cut-off Current
				Lead Acid	Li-ion	LiFePO4	
QA600A-12V25A	12V	17V	25A	14.7V	12.6V	14.6V	3.0A
QA600A-24V15A	24V	34V	15A	29.4V	29.4V	29.2V	1.5A
QA600A-24V20A	24V	34V	20A	29.4V	29.4V	29.2V	2.0A
QA600A-36V15A	36V	47V	15A	44.1V	42.0V	43.8V	1.5A
QA600A-48V10A	48V	66V	10A	58.8V	54.6V	58.4V	1.0A
QA600A-60V06A	60V	84V	06A	73.5V	67.2V	73.0V	1.0A

TECHNOLOGY PARAMETERS

AC Input Voltage Range	90-132V&180-264 47-63Hz		
AC Input Max Current	3.0A@220VAC		
Efficiency	≥92.0%		
Noise	≤45dB	Protection level	IP65

Product characteristics

SAFFTY	Active LLC technique is applied for a rapid respond on a fault; Quick active software self -protection and reliable passive hardware self-protection on VOLTAGE&CURRENT; Advanced charging strategy is integrated as a safeguard for battery system.
RELIABILITY	The shell is shaped by integrated die casting technique. And filled with special glue. The active cooling fan is also designed to be a fan with a potting structure and a longer life. Products of Charger Series have been operating in all kinds of industrial environment (Wet. Hot. Cold. High altitude) for more than ten years, the design is proved to pass the verification.
FUCTIONS	Three color indicator lights Three color indicator lights

SIZE AND WEIGHT&TEMPERATURE

Net Weight	1.7kg	Operating Temperature	-30℃—65℃
Storage Temperature	-40℃—95℃	Size	193*124*67

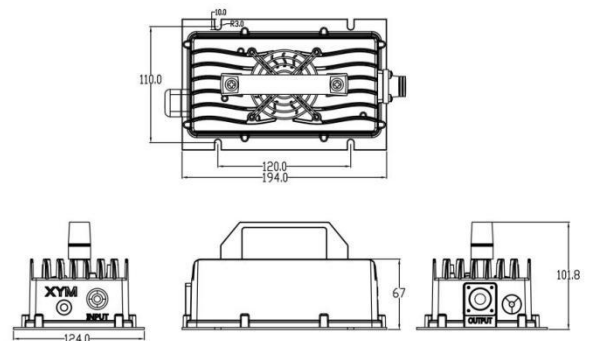

PROTECTION FUNCTIONS

Burnout Protection	Temperature of charger exceeds the limitation. The charge will low down the power load. Temperature of environment exceeds 65℃, the charger will stop charging and switch itself to standby mode until temperature of environment goes down.
Protection for Reverse Connection of Batteries	The circuit inside the charger shuts down with batteries when the batteries are connected reversely and will not damage the charger.
NO-load Protection	There is no output when the batteries are not connected.
Short Circuit Protection	The circuit inside the charger shuts down with batteries when output is short circuit. The charger will start charging only after troubleshooting and restart the charger.
Automatic shutdown when fully charging	The charging automatically turns off after the battery is fully charged according to the charger' s judgment.